



# **ED-HMI2120-101C**

## **User Manual**

by EDA Technology Co., Ltd

built: 2024-11-20

# 1 Hardware Manual

This chapter introduces the product overview, packing list, appearance, button, indicator and interface.

## 1.1 Overview

ED-HMI2120-101C is a 10.1-inch high reliability industrial HMI based on Raspberry Pi CM4. According to different application scenarios and user needs, different specifications of RAM and eMMC computer systems can be selected.

- Options for 1GB, 2GB, 4GB and 8GB RAM
- Options for 8GB, 16GB and 32GB eMMC storage

ED-HMI2120-101C provides common interfaces such as HDMI, USB 2.0, RS232, RS485, audio and Ethernet, and supports access to the network through Wi-Fi, Ethernet and 4G. ED-HMI2120-101C integrates supercapacitor (backup power supply, which is optional), RTC, Watch Dog, EEPROM and encryption chip, improving the ease of use and reliability of the product. It is mainly used in industrial control and IOT.



## 1.2 Packing List

- 1x ED-HMI2120-101C Unit
- 1 x Mounting Kit (including 4 x buckles, 4xM410 screws and 4xM416 screws)
- [optional Wi-Fi/BT version] 1x 2.4GHz/5GHz Wi-Fi/BT Antenna
- [optional 4G version] 1x 4G/LTE Antenna

## 1.3 Appearance

Introducing the functions and definitions of interfaces on each panel.

### 1.3.1 Front Panel

Introducing the front panel interface types and definitions.

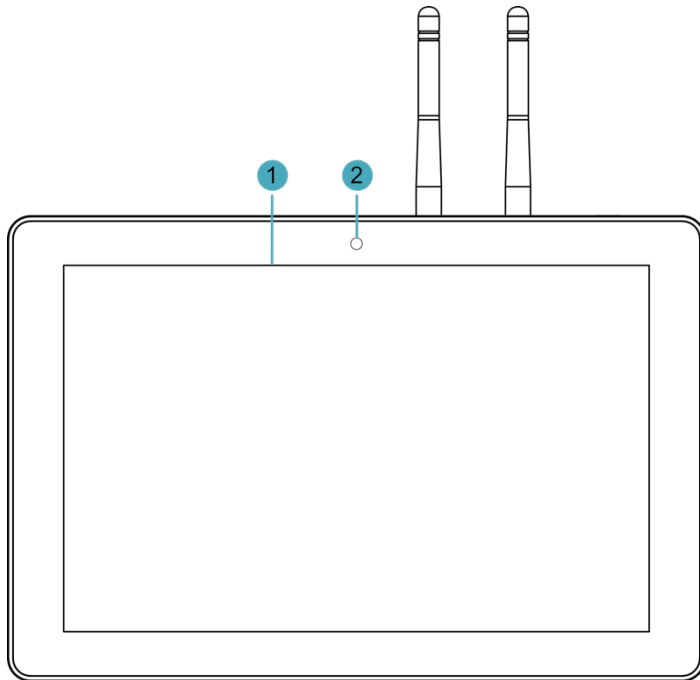

NO.	Function Definition
1	1 x LCD display, 10.1-inch LCD touch screen, which supports up to 1280x800 resolution and multi-point capacitive touchscreen.
2	1 x camera (optional), 8-megapixel front camera.

### 1.3.2 Rear Panel

Introducing the types and definitions of the rear panel interface.

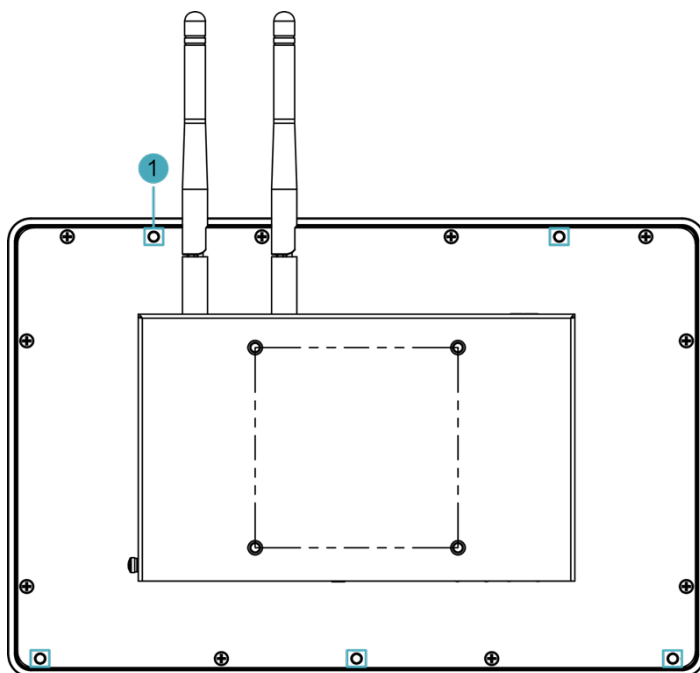

NO.	Function Definition
1	

NO.	Function Definition
	5 x installation holes of buckle, which are used to fix the buckles to the device for installation. You only need to use 4 installation holes during installation, and reserve one as a spare.

### 1.3.3 Side Panel

Introducing the types and definitions of side panel interfaces.

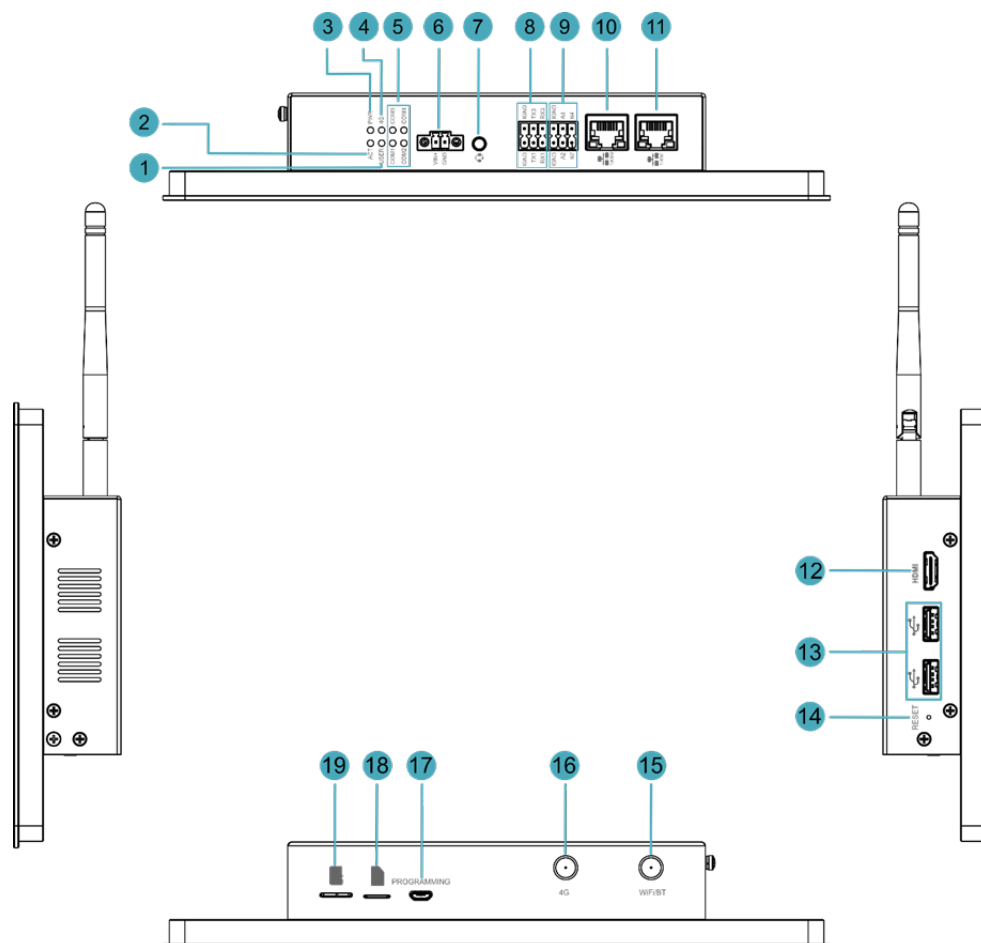

NO.	Function Definition
1	1 x green user indicator, user can customize a status according to actual application.
2	1 x green system status indicator, which is used to check the working status of device.
3	1 x red power indicator, which is used to check the status of device power-on and power-off.
4	1 x green 4G indicator, which is used to check the status of 4G signal.
5	4 x green UART indicators, using to check the communication status of UART port.
6	1 x DC input, 2-Pin 3.5mm pitch phoenix terminals with screw holes. It supports 9V~36V input, the signal is defined as VIN+/GND.
7	1 x Audio input/Stereo output, 3.5mm audio jack connector. It can be used as MIC IN and LINE OUT. <ul style="list-style-type: none"> <li>• When a headphone is connected, the audio output is switched to the headphone.</li> <li>• When a headphone is not connected, the audio output is switched to the speaker.</li> </ul>



NO.	Function Definition
8	2 x RS232 ports, 6-Pin 3.5mm pitch phoenix terminals, which is used to connect third-party control equipment.
9	2 x RS485 ports, 6-Pin 3.5mm pitch phoenix terminal, which is used to connect the third-party control equipment.
10	1 x 10/100/1000M adaptive ethernet port, RJ45 connector, with led indicator. It can be used to access the network.
11	1 x 10/100M adaptive ethernet port, RJ45 connector, with led indicator. It can be used to access the network.
12	1 x HDMI port, type A connector, which is compatible with HDMI 2.1 standard and supports 4K 60Hz. It supports to connect a displayer.
13	2 x USB 2.0 ports, type A connector, each channel supports up to 480Mbps transmission rate.
14	1 x Reset button, pressing the button will reset the device.
15	1 x Wi-Fi/BT antenna port, SMA connector, which can connect to Wi-Fi/BT antenna.
16	1 x 4G antenna port, SMA connector, which can connect to 4G antenna.
17	1 x Micro USB port, which supports to flash to eMMC for the system.
18	1 x Nano SIM slot, which is used to install a SIM card for getting 4G signal.
19	1 x Micro-SD card slot, which is used to install SD card for storing user data.

## 1.4 Button

ED-HMI2120-101C includes a RESET button, which is a hidden button, and the silkscreen on the case is "RESET". Pressing the RESET button will reset the device.

## 1.5 Indicator

Introducing the various statuses and meanings of indicators contained in ED-HMI2120-101C.

Indicator	Status	Description
PWR	On	The device has been powered on.
	Blink	Power supply of the device is abnormal, please stop the power supply immediately.
	Off	The device is not powered on.
ACT	Blink	The system started successfully and is reading and writing data.
	Off	The device is not powered on or does not read and write data.

Indicator	Status	Description
USER	On	User can customize a status according to actual application.
	Off	The device is not powered on or not defined by the user, and the default status is off.
4G	On	The dial-up is successful and the connection is normal.
	Off	4G signal is not connected or the device is not powered on.
Yellow indicator of Ethernet port	On	The data transmission is abnormal.
	Blink	Data is being transmitted over the Ethernet port.
	Off	The Ethernet connection is not set up.
Green indicator of Ethernet port	On	The Ethernet connection is in the normal state.
	Blink	The Ethernet connection is abnormal.
	Off	The Ethernet connection is not set up.
COM1~COM4	On/Blink	Data is being transmitted.
	Off	The device is not powered on or there is no data transmission.

## 1.6 Interface

Introducing the definition and function of each interface in the product.

### 1.6.1 Card Slot

ED-HMI2120-101C includes an SD card slot and a Nano SIM card slot.

#### 1.6.1.1 SD Card Slot

The silkscreen on the case of Micro SD card slot is "", which is used to install SD card for storing user data.

#### 1.6.1.2 SIM Card Slot

The silkscreen on the case of Nano SIM card slot is "", which is used to install SIM card for obtaining 4G signals.

### 1.6.2 Power Supply Interface

The ED-HMI2120-101C includes one power input, 2-Pin 3.5mm pitch phoenix terminals with screw holes. The silkscreen of port is "VIN+/GND", and the pins are defined as follows.

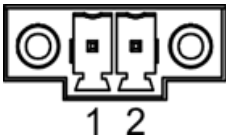
	Pin ID	Pin Name
	1	GND
	2	9V~36V

### 1.6.3 Audio Interface

ED-HMI2120-101C includes one audio input, the connector is a 3.5mm 4-pole headphone jack. The silkscreen of port is "", which supports OMTP stereo headphone output and mono microphone recording.

- When the headphone is connected, the audio output is switched to the headphone.
- When the headphone is not connected, the audio output is switched to the speaker.

### 1.6.4 Speaker

The ED-HMI2120-101C contains a power amplifier output, built-in a 4Ω 3W speaker, supporting single-channel stereo output. When playing audio, if the headphone is connected to the Audio interface, the speaker will have no audio output.

### 1.6.5 RS232 Interface

ED-HMI2120-101C include 2 RS232 ports, 6-Pin 3.5mm pitch phoenix terminals. The silkscreen of single RS232 is "IGND/TX/RX".

Pin Definition

Terminal pins are defined as follows:

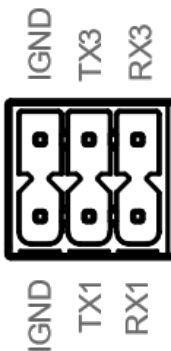
	Pin ID	Pin Name
	1	GND
	2	GND
	3	RS232-1_TX
	4	RS232-3_TX
	5	RS232-1_RX
6	RS232-3_RX	

The pin names of CM4 corresponding to RS232 interface are as follows:

Signal	CM4 GPIO Name	CM4 Pin Out
RS232-1_TX	GPIO4	UART3_TXD
RS232-3_TX	GPIO0	UART2_TXD

Signal	CM4 GPIO Name	CM4 Pin Out
RS232-1_RX	GPIO5	UART3_RXD
RS232-3_RX	GPIO1	UART2_RXD

## Connecting Cables

Schematic diagram of RS232 wires is as follows:

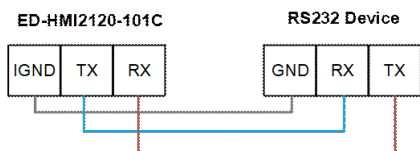

## 1.6.6 RS485

ED-HMI2120-101C include 2 RS485 ports, 6-Pin 3.5mm pitch phoenix terminals. The silkscreen of single RS485 is "IGND/A/B".

### Pin Definition

Terminal pins are defined as follows:

	Pin ID	Pin Name
	1	GND
	2	GND
	3	RS485-2_A
	4	RS485-4_A
	5	RS485-2_B
	6	RS485-4_B

The pin names of CM4 corresponding to RS485 interface are as follows:

Signal	CM4 GPIO Name	CM4 Pin Out
RS485-2_A	GPIO12	UART5_TXD
RS485-4_A	GPIO8	UART4_TXD
RS485-2_B	GPIO13	UART5_RXD
RS485-4_B	GPIO9	UART4_RXD

## Connecting Cables

Schematic diagram of RS485 wires is as follows:

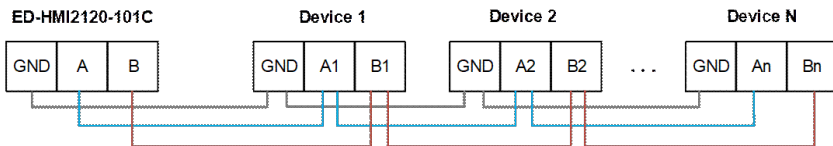

RS485 terminal resistance configuration

ED-HMI2120-101C contain 2 RS485 ports. A 120R jumper resistor is reserved between A and B of RS485 line. The jumper cap can be inserted to enable the jumper resistor. By default, the jumper cap is not connected, and the 120R jumper resistor function is disabled. The position of jumper resistor in the PCBA are J24 and J22 in the figure below (red box position).

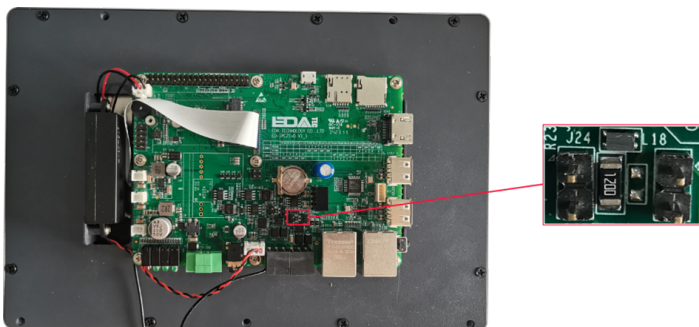

The relationship between the RS485 ports and corresponding COM ports are shown in the table below.

Location in PCBA	Corresponding COM port	The specific location of the corresponding COM
J24	COM4	
J22	COM2	

**TIP**

You need to open the device case to view the position of 120R jumper resistor. For detailed operations, please refer to [2.1.1 Open Device Case](#).

### 1.6.7 1000M Ethernet Interface

ED-HMI2120-101C includes one adaptive 10/100/1000M Ethernet port, and the silkscreen is

"1000M". The connector is RJ45, which can support PoE with the expansion module. When accessing to network, it is recommended to use the network cable of Cat6 and above. The pins corresponding to the terminal are defined as follows:

	Pin ID	Pin Name
	1	TX1+
	2	TX1-
	3	TX2+

4	TX2-
5	TX3+
6	TX3-
7	TX4+
8	TX4-

## 1.6.8 100M Ethernet Interface

ED-HMI2120-101C includes includes an adaptive 10/100M Ethernet port, and the silkscreen is



"100M". The connector is RJ45, and it is recommended to use the network cable with Cat6 and above when accessing to network. The pins corresponding to the terminal are defined as follows:

	Pin ID	Pin Name
	1	TX+
	2	TX-
	3	Rx+
	4	-
	5	-
	6	RX-
	7	-
8	-	

## 1.6.9 HDMI Interface

ED-HMI2120-101C includes one HDMI port, the silkscreen is "HDMI". The connector is type A HDMI, which can connect to an HDMI display and supports up to 4Kp60.

## 1.6.10 USB 2.0 Interface

ED-HMI2120-101C includes 2 USB2.0 ports, the silkscreen is "". The connector is type A USB, which can connect to standard USB 2.0 peripherals and supports up to 480Mbps transmission rate.

## 1.6.11 Micro USB Interface

ED-HMI2120-101C includes one Micro USB interface, the silkscreen is "PROGRAMMING" and it can be connected to a PC to flash to eMMC of the device.

## 1.6.12 Antenna Interface (optional)

The ED-HMI2120-101C includes 2 SMA antenna ports, the silkscreens are "4G" and "Wi-Fi/BT" and they can be connected to the 4G antenna and Wi-Fi/BT antenna.

### TIP

The number of antenna interface is related to the purchasing product model. Here, we take two antenna interfaces as an example.

## 1.6.13 Motherboard Interface

Introducing the interfaces reserved in the ED-HMI2120-101C, which can be obtained only after the device case is opened and can be expanded according to actual needs.

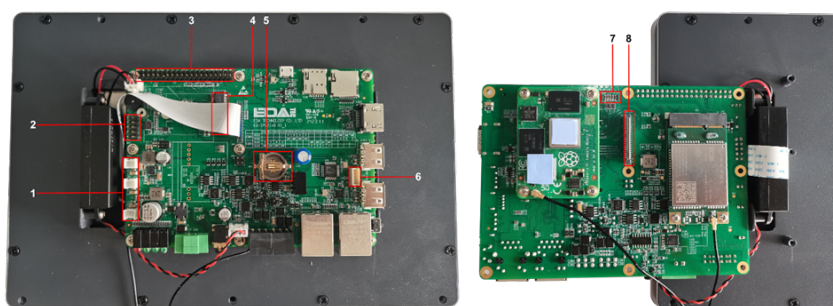

NO.	Function
1	12V 1A Power Output
2	10-Pin GPIO Pin Header
3	40-Pin GPIO Pin Header
4	M.2 B
5	RTC Battery Base
6	USB 2.0 Pin Header
7	CSI Interface
8	FPC HDMI Interface

### 1.6.13.1 12V 1A Output

The motherboard of ED-HMI2120-101C includes 3 expanded 12V 1A power output ports with 2-Pin 2.0mm white WTB connector, which is reserved for the extended LCD screen to supply power. The pins are defined as follows:

	Pin ID	Pin Name

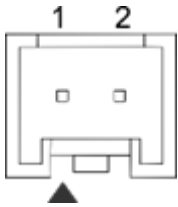
	1	GND
	2	12V

### 1.6.13.2 10-Pin GPIO

The motherboard of ED-HMI2120-101C includes a 10-Pin GPIO Pin Header with 2x5-Pin 2.54mm pitch, which is used to lead out the extended GPIO port. The user can customize the extension, and the pins definition are as follows:

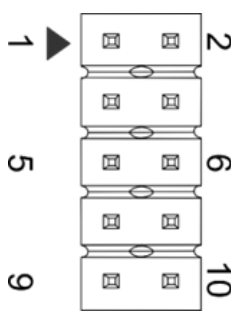
	Pin ID	Pin Name
	1	EXIO_P10
	2	3V3
	3	EXIO_P12
	4	EXIO_P11
	5	EXIO_P14
	6	EXIO_P13
	7	EXIO_P16
	8	EXIO_P15
	9	GND
10	EXIO_P17	

### 1.6.13.3 40-Pin GPIO

The motherboard of ED-HMI2120-101C includes a 40-Pin GPIO terminal with 2x20-Pin 2.54mm pitch, which is used to lead out the GPIO port of CM4, and reserves to connect the extended accessories. The pins are defined as follows:

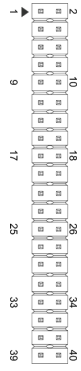
	Pin ID	Pin Name	Pin ID	Pin Name
	1	3V3_EXT	2	5V2_CM4
	3	GPIO2	4	5V2_CM4
	5	GPIO3	6	GND
	7	GPIO4	8	GPIO14
	9	GND	10	GPIO15
	11	GPIO17	12	GPIO18



13	GPIO27	14	GND
15	GPIO22	16	GPIO23
17	3V3_EXT	18	GPIO24
19	GPIO10	20	GND
21	GPIO9	22	GPIO25
23	GPIO11	24	GPIO8
25	GND	26	GPIO7
27	GPIO0	28	GPIO1
29	GPIO5	30	GND
31	GPIO6	32	GPIO12
33	GPIO13	34	GND
35	GPIO19	36	GPIO16
37	GPIO26	38	GPIO20
39	GND	40	GPIO21

Note:GPIO4~GPIO9、GPIO12、GPIO13 and GPIO22~GPIO27 has been used for other specific functions. If you need to use the function of its ordinary IO, you need to remove the jumper resistance on the corresponding signal line.

### 1.6.13.4 M.2 B Interface

The motherboard of ED-HMI2120-101C includes a M.2 B Key connector, which is used for external SSD. It is compatible with M.2 B 2230 and M.2 B 2242 SSD.

### 1.6.13.5 RTC Battery Base

The motherboard of ED-HMI2120-101C is integrated with RTC. For the version sold in China, we will install CR1220 battery (RTC backup power supply) by default.

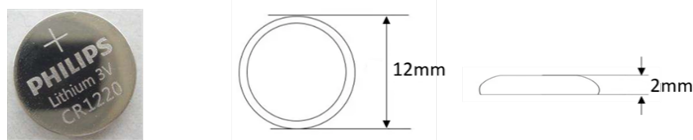

RTC can ensure that the system has an uninterrupted and reliable clock, which is not affected by factors such as the device is power down.

**TIP**

Some international logistics do not support the transportation of batteries, and some ex-factory devices are not equipped with CR1220 batteries. Therefore, before using RTC, please prepare a CR1220 battery and install it on the motherboard.

**1.6.13.6 USB 2.0 Interface**

The motherboard of ED-HMI2120-101C includes an extended USB 2.0 Pin Header with 5-Pin 1.5mm pitch WTB connector. It is used to expand a USB 2.0 interface, the pins are defined as follows:

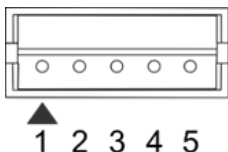
	Pin ID	Pin Name
	1	VBUS
	2	USB_DM
	3	USB_DP
	4	GND
	5	GND

**1.6.13.7 CSI Interface**

The motherboard of ED-HMI2120-101C includes one extended CSI interface, 2x15-Pin 0.4mm pitch connector and 2-Lane CSI signal. It is used to expand the connection of 8-megapixels CSI camera, the pins are defined as follows:

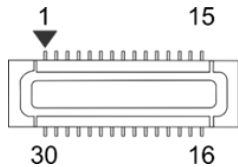
	Pin ID	Pin Name	Pin ID	Pin Name
	1	NC	2	NC
	3	1V8_CM4	4	1V2_CSI
	5	1V8_CM4	6	GND
	7	CSI_MCLK	8	GND
	9	GND	10	2V8_CSI
	11	NC	12	NC
	13	NC	14	NC
	15	GND	16	GND
	17	NC	18	NC
	19	GND	20	CSI_D1_N
	21	CSI_D1_P	22	GND

23	CSI_D0_N	24	CSI_D0_P
25	GND	26	CSI_CLK_N
27	CSI_CLK_P	28	GND
29	SCL_1V8	30	SDA_1V8

### 1.6.13.8 FPC HDMI Interface

The motherboard of ED-HMI2120-101C includes one extended HDMI interface with 40-pin 0.5mm pitch FPC connector. It supports video signal output to LCD screen, reserves to connect the extended LCD screen. It supports USB/I2C touch screen and backlight adjustment. The pins are defined as follows:

Pin ID	Pin Name	Pin ID	Pin Name
1	NC	2	NC
3	NC	4	NC
5	NC	6	NC
7	NC	8	GND
9	HDMI1_CLKN	10	HDMI1_CLKP
11	GND	12	GND
13	HDMI1_TX0N	14	HDMI1_TX0P
15	GND	16	GND
17	HDMI1_TX1N	18	HDMI1_TX1P
19	GND	20	GND
21	HDMI1_TX2N	22	HDMI1_TX2P
23	GND	24	GND
25	HDMI1_CEC	26	GND
27	HDMI1_SCL	28	HDMI1_SDA
29	GND	30	HDMI1_HPD
31	GND	32	TPINT_L
33	GND	34	SDA_LCD
35	SCL_LCD	36	GND
37	GND	38	USB_DP_LCD
39	USB_DM_LCD	40	GND

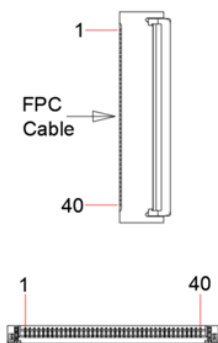



## 2 Installing Components (optional)

This chapter describes how to install optional components.

### 2.1 Installing Internal Components (optional)

Introducing the detailed operations of opening/closing the device case and installing the RTC battery. Before installing the internal components, it is necessary to open the device case.

#### 2.1.1 Open Device Case

Preparation:

A cross screwdriver has been prepared.

Steps:

1. Pull out the default configuration of phoenix connector (male for wiring).
2. Use a screwdriver to loosen two M3 screws on two sides counterclockwise.

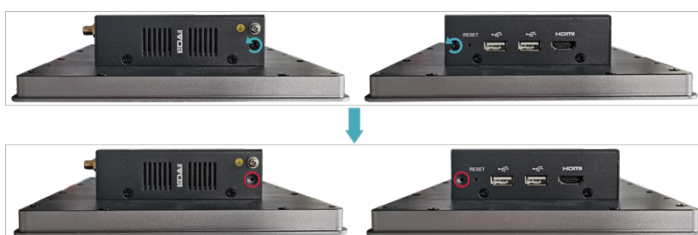

3. Remove the side cover to the right.

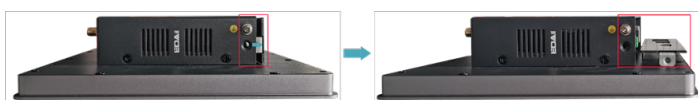

4. Use a screwdriver to loosen four M3 screws and one grounding screw on two sides counterclockwise.

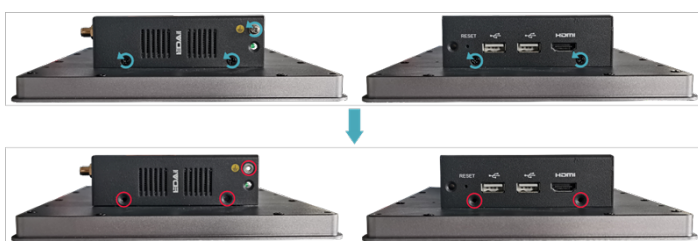

5. Remove the metal case upward and turn it to the ports side.

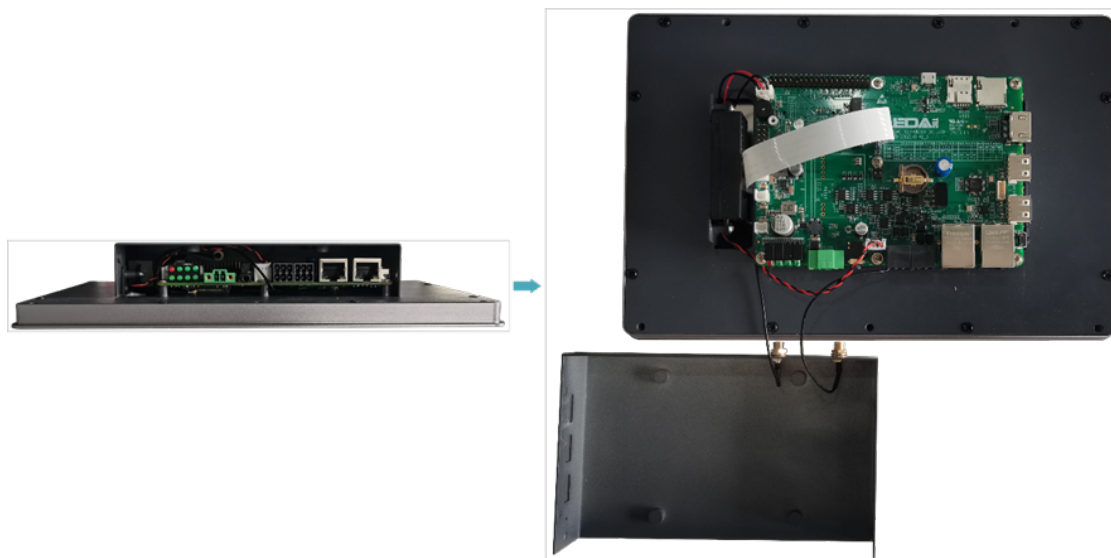

6. Use a screwdriver to loosen the 8 screws fixing the PCBA counterclockwise, and flip it to the back of the PCBA.

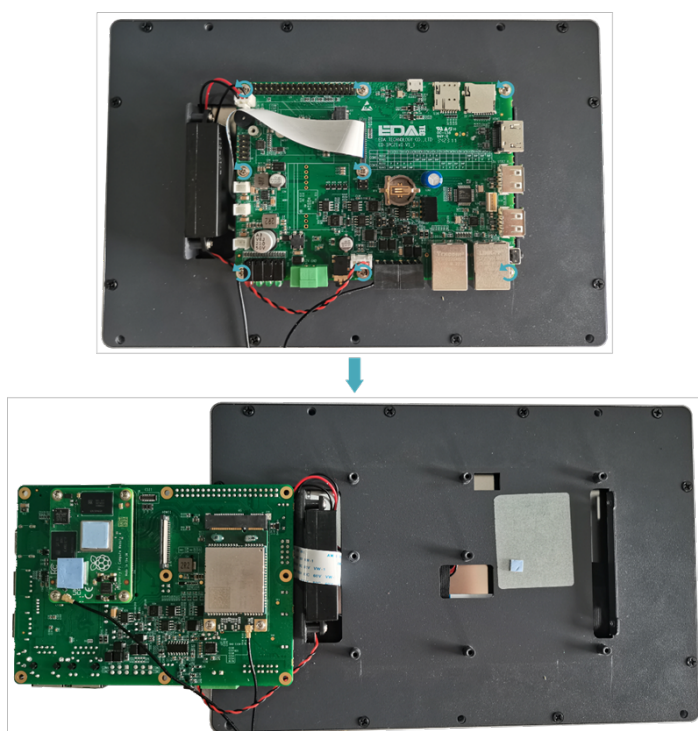

## 2.1.2 Install RTC battery

### TIP

Some international logistics do not support the transportation of batteries, and some ex-factory devices are not equipped with CR1220 batteries. Therefore, before using RTC, please prepare a CR1220 battery and install it on the motherboard.

Preparation:

- The device case has been opened.
- The CR1220 battery has been prepared.

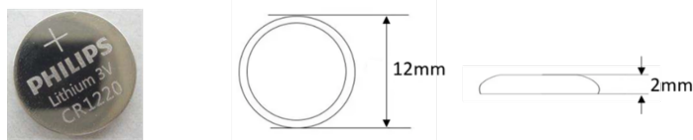

Steps:

1. Locate the RTC battery base where the battery is to be installed, as shown in the red box below.

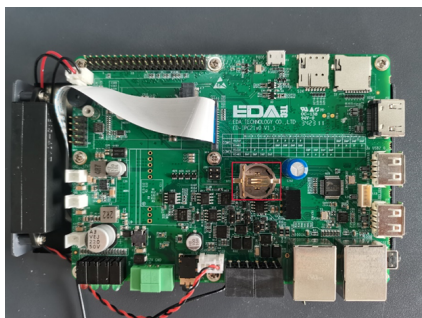

2. Put the positive pole of the battery upwards and press it into the RTC base. The installation effect is as shown below.

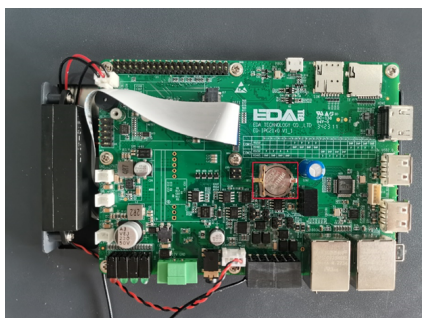

## 2.1.3 Close Device Case

Preparation:

A cross screwdriver has been prepared.

Steps:

1. Turn the PCBA over to the front and place it on the back of the LCD screen. Align the 8 screw holes on the PCBA with the stud holes on the back of the LCD screen. Insert the 8 mounting screws, and then use a screwdriver to tighten clockwise to fix the PCBA on the on the back of the LCD screen.



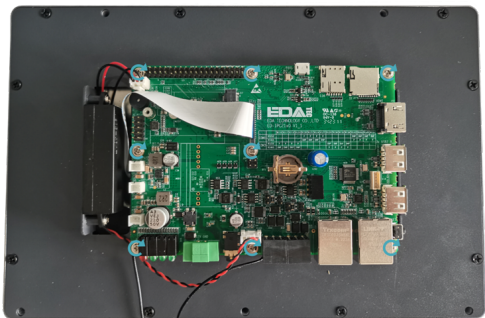

2. Flip the metal case upward, align the screw mounting holes on the metal case with the screw mounting holes on the back of the LCD screen, and cover it downward on the back of the LCD screen.



3. Align the screw holes on side panels of metal case, insert 4 M3 screws and one grounding screw, then tighten clockwise with a screwdriver.

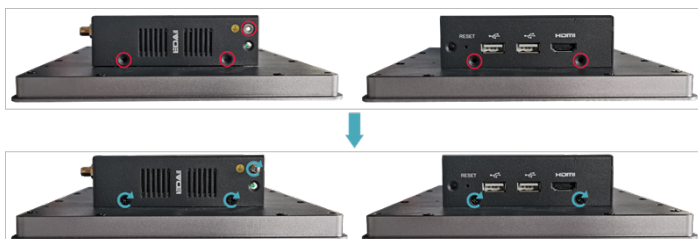

4. Align the ports on PCBA with the ports on the side panel, insert the side cover.



5. Insert 2 M3 screws and then use a screwdriver to tighten two M3 screws clockwise.



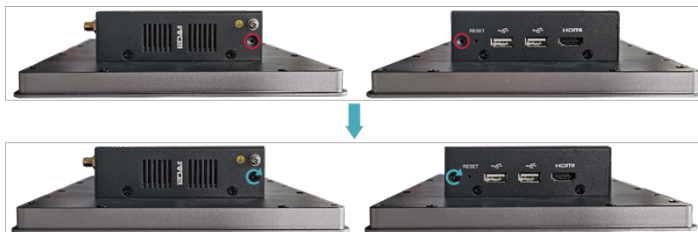

6. Plug in the default phoenix connector.

## 2.2 Installing/Removing External Components

Introducing the detailed operations of installing/removing some optional accessories.

### 2.2.1 Install Antenna

If the purchasing ED-HMI2120-101C includes 4G and Wi-Fi functions, the antenna need to be installed before using the device.

Preparation:

The corresponding antennas have been obtained from the packaging box. If there are multiple antennas, they can be distinguished by the labels on the antennas.

Steps:

1. Find the location of antenna port, as shown in the red mark of figure below.



2. Align the ports on both sides of the device and the antenna and tighten them clockwise to ensure that they will not fall off.

### 2.2.2 Install Micro SD Card

If you need to install the SD card while using the product, you can refer to the following instructions.

Preparation:

SD card is ready.

Steps:

1. Find the location of SD card slot, as shown in the red mark of figure below.



2. Insert the Micro SD card into the corresponding card slot with the contact side facing down, and hear a sound to indicate that the installation is completed.



## 2.2.4 Pull Out SD Card

If you need to remove the SD card while using the product, you can refer to the following instructions.

Steps:

1. Find the location of SD card, as shown in the red mark of figure below.



2. Press the SD card into the card slot with your hand to pop it out, and then pull out the SD card.



## 2.2.4 Install Nano SIM Card

If the purchasing ED-HMI2120-101C device includes 4G function, the SIM card need to be installed before using 4G.

Preparation:

The 4G Nano SIM card is ready.

Steps:

1. Find the location of Nano SIM card slot, as shown in the red mark of figure below.



2. Insert the Nano SIM card into the corresponding card slot with the chip side up, and hear a sound to indicate that the installation is completed.



## 3 Installing Device

This chapter introduces how to install the device.

### 3.1 Embedded Installation

ED-HMI2120-101C supports embedded front installation, which is equipped with a Mounting Kit (including 4 x buckles, 4xM4\*10 screws and 4xM4\*16 screws) .

Preparation:

- A Mounting Kit (including 4 x buckles, 4xM4\*10 screws and 4xM4\*16 screws) have been obtained from the packaging box.
- A cross screwdriver has been prepared.

Steps:

1. You need ensure the opening size of the cabinet according to the size of ED-HMI2120-101C, as shown in the figure below.

Unit: mm



2. Drill a hole on the cabinet according to the hole size of step1.
3. Insert the ED-HMI2120-101C into the cabinet from the outside.

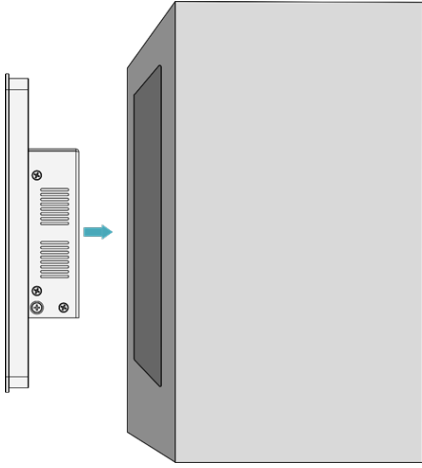

4. Align the screw hole (unthreaded hole) of the buckle with the buckle mounting hole on the side of the device.

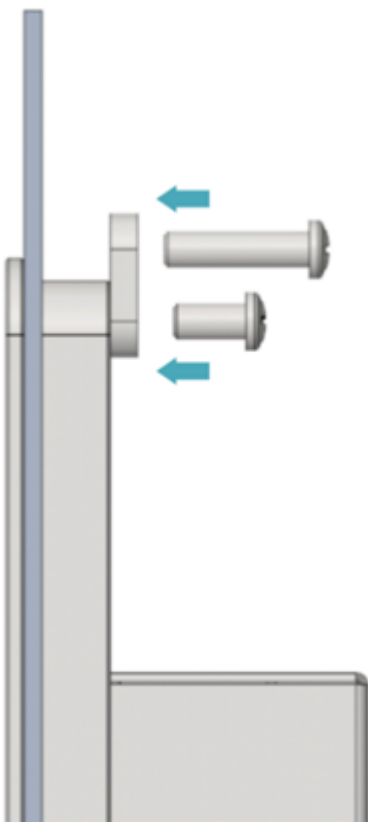

5. Use 4 M4\*10 screws to pass through the buckle and tighten it clockwise to fix the buckle to the device; then use 4 M4\*16 screws to pass through the screw hole (threaded hole) of the buckle and tighten clockwise to the end through the buckles.

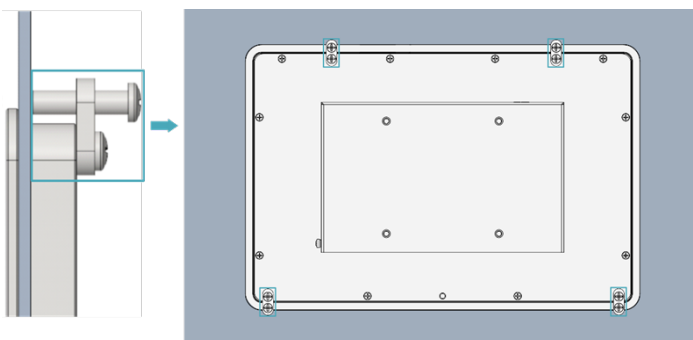



## 4 Booting the Device

This chapter introduces how to connect cables and boot the device.

### 4.1 Connecting Cables

This section describes how to connect cables.

Preparation:

- Accessories such as display, mouse, keyboard and power adapter that can be used normally have been ready.
- A network that can be used normally.
- Get the HDMI cable and network cable that can be used normally.

Schematic diagram of connecting cables:

Please refer to [1.6 Interfaces](#) for the pin definition of each interface and the specific method of wiring.

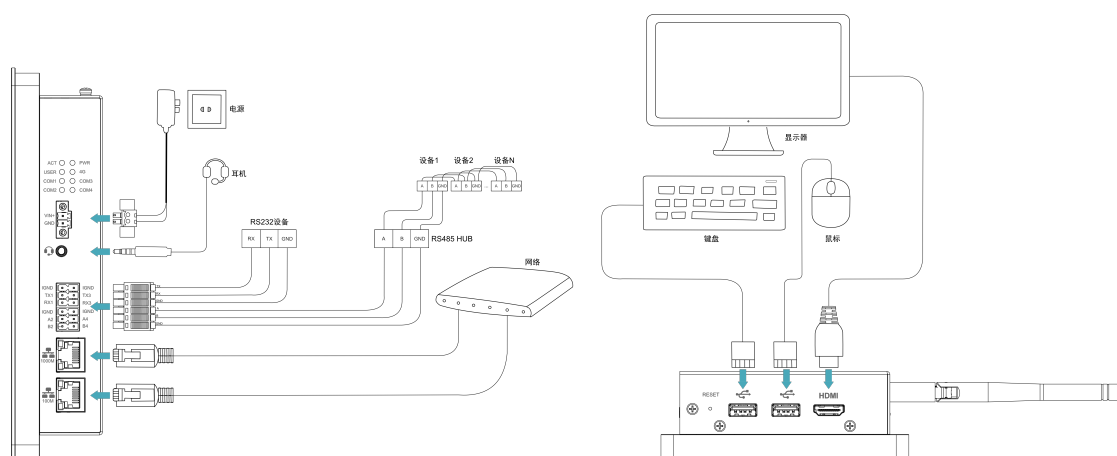

### 4.2 Booting The System For The First Time

ED-HMI2120-101C has no switching power supply. After the power supply is connected, the system will start.

- The red PWR indicator is on, indicating that the device has been powered normally.
- The green ACT indicator is blinking, indicating that the system is started normally, and then the logo of Raspberry Pi will appear in the upper left corner of the screen.

#### TIP

Default username is `pi` , Default password is `raspberrypi` .

## 4.2.1 Raspberry Pi OS (Desktop)

If the Desktop version of the system is installed when the product leaves the factory, after the device is started, it will directly enter the desktop, as shown in the following figure.

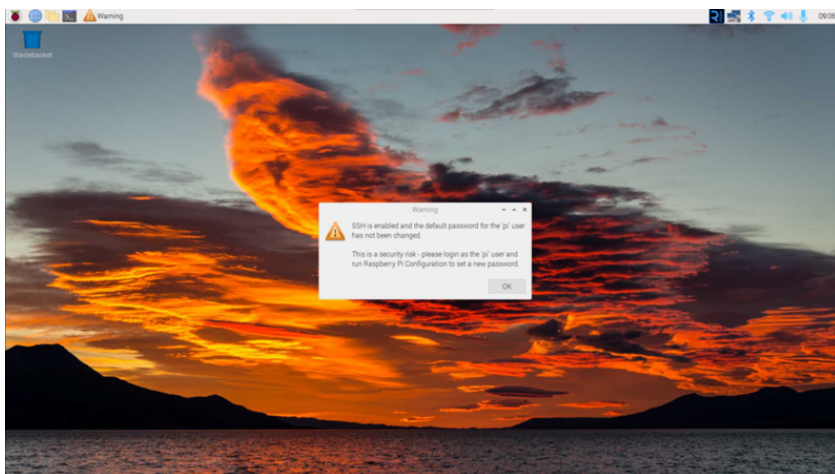

## 4.2.2 Raspberry Pi OS (Lite)

If the Lite version of the system is installed at the factory, the default username pi will be used to automatically log in after the device is started, and the default password is raspberry. The following figure shows that the system has been started normally.

```
[ OK ] Started LSB: rng-tools (Debian variant).
[ OK ] Started WPA supplicant.
[ OK ] Started Authorization Manager.
[ OK ] Reached target Network.
[ OK ] Listening on Load/Save RF #itch Status /dev/rfkill Watch.
Starting Modem Manager...
Starting /etc/rc.local Compatibility...
Starting Permit User Sessions...
[ OK ] Finished Remove Stale OnlimeX4 Metadata Check Snapshots.
[ OK ] Started /etc/rc.local Compatibility.
Starting Load/Save RF Kill Switch Status...
[ OK ] Finished Permit User Sessions.
[ OK ] Started Getty on tty1.
[ OK ] Reached target Login Prompts.
[ OK ] Started Load/Save RF Kill Switch Status.
[ OK ] Started User Login Management.
Starting Save/Restore Sound Card State...
[ OK ] Finished Save/Restore Sound Card State.
[ OK ] Reached target Sound Card.
[ OK ] Started Modem Manager.
[ OK ] Started LSB: Switch to omd*(unless shift key is pressed).

Raspbian GNU/Linux 11 raspberrypi tty1
raspberrypi login: pi
Password:
Linux raspberrypi 6.1.21-00* #1642 SMP PREEMPT Mon Apr 3 17:24:16 BST 2023 aarch64

The programs included with the Debian GNU/Linux system are free software;
the exact distribution terms for each program are described in the
individual files in /usr/share/doc/*/*copyright.

Debian GNU/Linux comes with ABSOLUTELY NO WARRANTY, to the extent
permitted by applicable law.
Last login: Tue Jul 11 11:15:20 BST 2023 on tty1

Wi-Fi is currently blocked by rfkill.
Use raspi-config to set the country before use.

pi@raspberrypi:~$
```



# 5 Configuring System

This chapter introduces how to configure system.

## 5.1 Finding Device IP

Finding Device IP

## 5.2 Remote Login

Remote Login

## 5.3 Configuring Storage Devices

Configuring Storage Devices

## 5.4 Configuring Ethernet IP

Configuring Ethernet IP

## 5.5 Configuring Wi-Fi (Optional)

Configuring Wi-Fi

## 5.6 Configuring Bluetooth (Optional)

Configuring Bluetooth

## 5.7 Configuring 4G (Optional)

Configuring 4G

## 5.8 Configuring Buzzer

Configuring Buzzer

## 5.9 Configuring RTC

Configuring RTC

## 5.10 Configuring Serial Port

This chapter introduces the configuration method of RS232 and RS485.

### 5.10.1 Installing picocom tool

In the Linux environment, you can use the picocom tool to debug the serial ports RS232 and RS485.

Execute the following command to install the picocom tool.

```
sudo apt-get install picocom
```

sh

### 5.10.2 Configuring RS232

ED-HMI2120-101C includes 2 RS232 ports, and the corresponding COM ports and device files are as follows:

Number of RS232 Ports	Corresponding COM Port	Corresponding Device File
2	COM1, COM3	/dev/com1, /dev/com3

Preparation:

The RS232 port of ED-HMI2120-101C has been connected with external device.

Steps:

1. Execute the following command to open the serial port com1, and configure the serial port baud rate to 115200.

```
picocom -b 115200 /dev/com1
```

sh

2. Input commands as needed to control external device.

### 5.10.3 Configuring RS485

ED-HMI2120-101C includes 2 RS485 ports, and the corresponding COM ports and device files are as follows:

Number of RS485 Ports	Corresponding COM Port	Corresponding Device File
2	COM2, COM4	/dev/com2, /dev/com4

Preparation:

The RS485 port of ED-HMI2120-101C has been connected with external devices.

Steps:

1. Execute the following command to open the serial port com4, and configure the serial port baud rate to 115200.

```
picocom -b 115200 /dev/com4
```

sh

2. Input commands as needed to control external devices.

## 5.11 Configuring Audio (Optional)

Configuring Audio

## 5.12 Configuring USER Indicator

Configuring USER Indicator

## 6 Installing OS (optional)

The device is shipped with an operating system by default. If the OS is corrupted during use or the user needs to replace the OS, it is necessary to re-download the appropriate system image and install it. Our company supports to install the OS by installing the standard Raspberry Pi OS first, and then install the Firmware package.

The following section describes the specific operations of image download, eMMC flashing and installation of Firmware packages.

### 6.1 Downloading OS File

You can download the corresponding official Raspberry Pi OS file according to your actual needs, the download path is listed below:

OS	Download Path
Raspberry Pi OS(Desktop) 64-bit-bookworm (Debian 12)	<a href="https://downloads.raspberrypi.com/raspios_arm64/images/raspios_arm64-2024-07-04/2024-07-04-raspios-bookworm-arm64.img.xz">https://downloads.raspberrypi.com/raspios_arm64/images/raspios_arm64-2024-07-04/2024-07-04-raspios-bookworm-arm64.img.xz</a> ( <a href="https://downloads.raspberrypi.com/raspios_arm64/images/raspios_arm64-2024-07-04/2024-07-04-raspios-bookworm-arm64.img.xz">https://downloads.raspberrypi.com/raspios_arm64/images/raspios_arm64-2024-07-04/2024-07-04-raspios-bookworm-arm64.img.xz</a> )
Raspberry Pi OS(Lite) 64-bit-bookworm (Debian 12)	<a href="https://downloads.raspberrypi.com/raspios_lite_arm64/images/raspios_lite_arm64-2024-07-04/2024-07-04-raspios-bookworm-arm64-lite.img.xz">https://downloads.raspberrypi.com/raspios_lite_arm64/images/raspios_lite_arm64-2024-07-04/2024-07-04-raspios-bookworm-arm64-lite.img.xz</a> ( <a href="https://downloads.raspberrypi.com/raspios_lite_arm64/images/raspios_lite_arm64-2024-07-04/2024-07-04-raspios-bookworm-arm64-lite.img.xz">https://downloads.raspberrypi.com/raspios_lite_arm64/images/raspios_lite_arm64-2024-07-04/2024-07-04-raspios-bookworm-arm64-lite.img.xz</a> )
Raspberry Pi OS(Desktop) 32-bit-bookworm (Debian 12)	<a href="https://downloads.raspberrypi.com/raspios_armhf/images/raspios_armhf-2024-07-04/2024-07-04-raspios-bookworm-armhf.img.xz">https://downloads.raspberrypi.com/raspios_armhf/images/raspios_armhf-2024-07-04/2024-07-04-raspios-bookworm-armhf.img.xz</a> ( <a href="https://downloads.raspberrypi.com/raspios_armhf/images/raspios_armhf-2024-07-04/2024-07-04-raspios-bookworm-armhf.img.xz">https://downloads.raspberrypi.com/raspios_armhf/images/raspios_armhf-2024-07-04/2024-07-04-raspios-bookworm-armhf.img.xz</a> )
Raspberry Pi OS(Lite) 32-bit-bookworm (Debian 12)	<a href="https://downloads.raspberrypi.com/raspios_lite_armhf/images/raspios_lite_armhf-2024-07-04/2024-07-04-raspios-bookworm-armhf-lite.img.xz">https://downloads.raspberrypi.com/raspios_lite_armhf/images/raspios_lite_armhf-2024-07-04/2024-07-04-raspios-bookworm-armhf-lite.img.xz</a> ( <a href="https://downloads.raspberrypi.com/raspios_lite_armhf/images/raspios_lite_armhf-2024-07-04/2024-07-04-raspios-bookworm-armhf-lite.img.xz">https://downloads.raspberrypi.com/raspios_lite_armhf/images/raspios_lite_armhf-2024-07-04/2024-07-04-raspios-bookworm-armhf-lite.img.xz</a> )

### 6.2 Flashing to eMMC

It is recommended to use the Raspberry Pi official tools. The download paths are as follows:

- Raspberry Pi Imager: [https://downloads.raspberrypi.org/imager/imager\\_latest.exe](https://downloads.raspberrypi.org/imager/imager_latest.exe) ([https://downloads.raspberrypi.org/imager/imager\\_latest.exe](https://downloads.raspberrypi.org/imager/imager_latest.exe))

- SD Card Formatter: <https://www.sdcardformatter.com/download/> (<https://www.sdcardformatter.com/download/>)
- Rpiboot: [https://github.com/raspberrypi/usbboot/raw/master/win32/rpiboot\\_setup.exe](https://github.com/raspberrypi/usbboot/raw/master/win32/rpiboot_setup.exe) ([https://github.com/raspberrypi/usbboot/raw/master/win32/rpiboot\\_setup.exe](https://github.com/raspberrypi/usbboot/raw/master/win32/rpiboot_setup.exe))

## Preparation:

- The downloading and installation of the official tools to the computer have been completed.
- A Micro USB to USB-A cable has been prepared.
- The OS file has been obtained.

## Steps:

The steps are described using Windows system as an example.

### 1. Connect the power cord and USB flashing cable (Micro-USB to USB-A).

- Connecting to USB cable: One end is connected to the Micro USB port on the device side, and the other end is connected to the USB port on the PC.
- Connecting to power cord: One end is connected to the DC 2Pin Phoenix terminal on the device side, and the other end is connected to the external power supply.

### 2. Disconnect the power supply of ED-HMI2120-101C and then power it on again.

### 3. Open rpiboot tool to automatically convert the drive to a letter

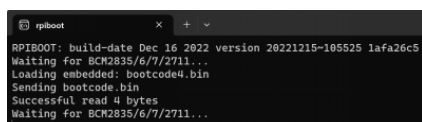

```

rpiboot
RPIBOOT: build-date Dec 16 2022 version 20221215-105525 lafa26c5
Waiting for BCM2835/6/7/2711...
Loading embedded: bootcode4.bin
Sending bootcode_bin
Successful read 4 bytes
Waiting for BCM2835/6/7/2711...

```

### 4. After the completion of the drive letter, the drive letter will pop up in the lower right corner of the computer.

### 5. Open SD Card Formatter, select the formatted drive letter, and click "Format" at the lower right to format.

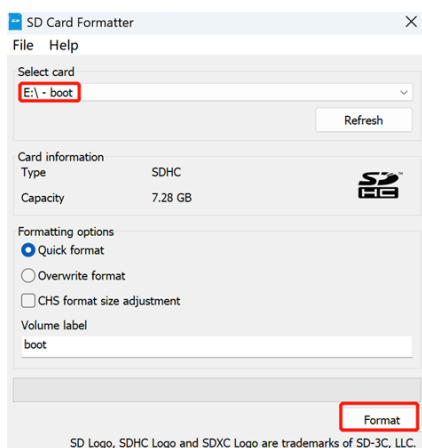

### 6. In the pop-up prompt box, select "Yes".

### 7. When the formatting is completed, click "OK" in the prompt box.

### 8. Close SD Card Formatter.

### 9. Open Raspberry Pi Imager, select "CHOOSE OS" and select "Use Custom" in the pop-up pane.

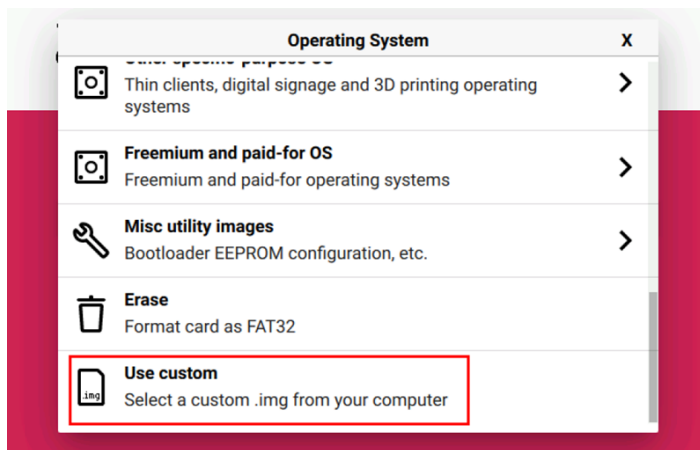

10. According to the prompt, select the OS file under the user-defined path and return to the main page.
11. Click "CHOOSE STORAGE", select the default device in the "Storage" interface, and return to the main page.

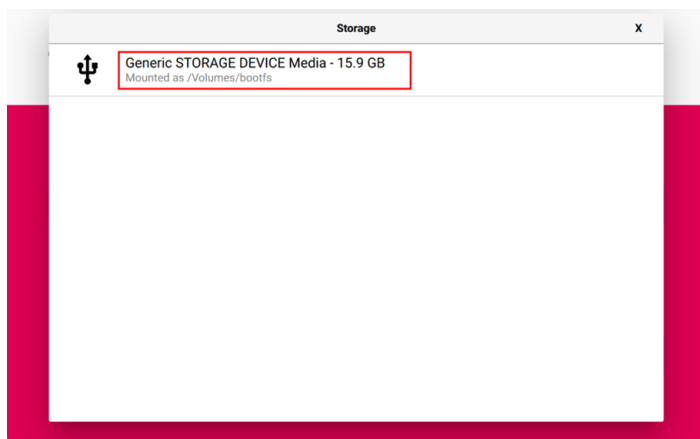

12. Click "NEXT", select "NO" in the pop-up "Use OS customization?" pane.

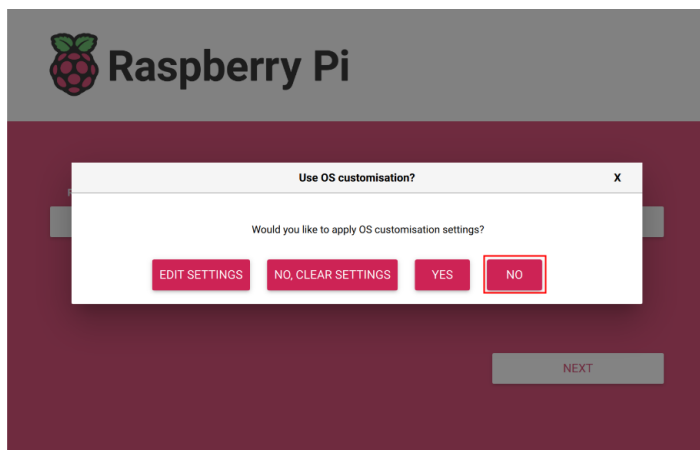

13. Select "YES" in the pop-up "Warning" pane to start writing the image.

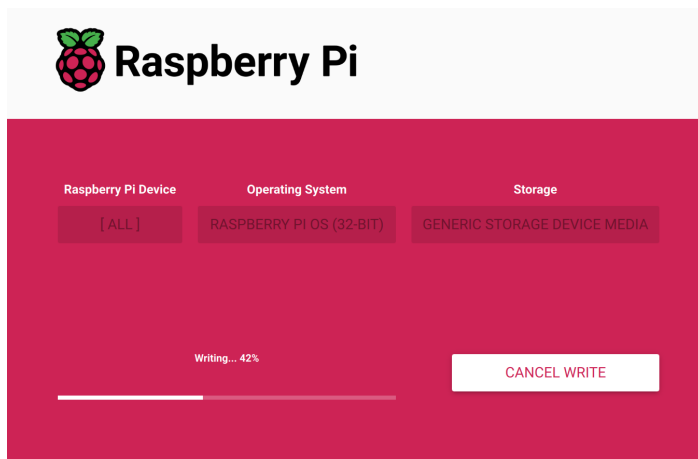

14. After the OS writing is completed, the file will be verified.

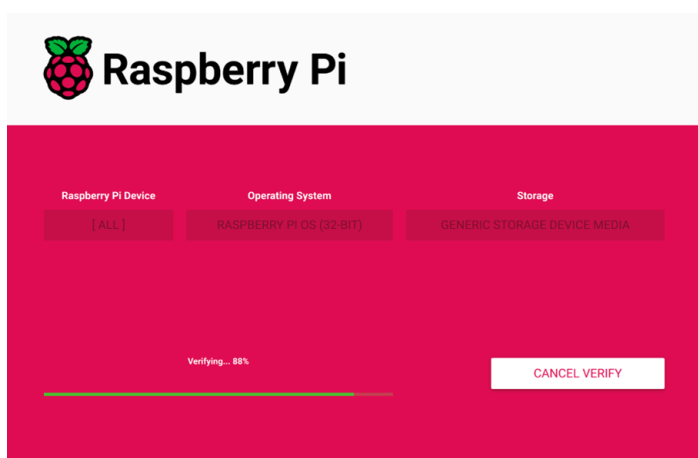

15. After the verification is completed, click “CONTINUE” in the pop-up “Write Successful” box.

16. Close Raspberry Pi Imager, remove USB cable and power on the device again.

## 6.3 Installing Firmware Package

After you have finished flashing to eMMC on ED-HMI2120-101C, you need to configure the system by adding edatec apt source and installing firmware package to make the system work. The following is an example of Debian 12 (bookworm) desktop version.

Preparation:

- The flashing to eMMC of the Raspberry Pi standard OS (bookworm) has been completed.
- The device has booted normally and the relevant boot configuration has been completed.

Steps: :

1. After the device starts normally, execute the following commands in the command pane to add the edatec apt source and installing firmware package.

```
curl -s https://apt.edatec.cn/bsp/ed-install.sh | sudo bash -s hmi2120_101c
```

sh

```

pi@raspberrypi:~$ curl -s https://apt.edatec.cn/bsp/ed-install.sh | sudo bash -s hmt2120_101c
  % Total    % Received % Xferd  Average Speed   Time    Time     Time  Current
                                 Dload  Upload   Total   Spent    Left   Speed
100 399 100 399 0 0 1172 0 --:--:-- --:--:-- --:--:-- 1173
--2024-10-16 16:51:38-- https://apt.edatec.cn/bsp/splash.png
Connecting to 192.192.192.208:8118... connected.
Proxy request sent, awaiting response... 200 OK
Length: 36009 (35K) [image/png]
Saving to: '/tmp/eda-common/eda/splash.png'

/tmp/eda-common/eda/splash.png 100%[=====] 35.17K --.-KB/s in 0.02s
2024-10-16 16:51:38 (2.19 MB/s) - '/tmp/eda-common/eda/splash.png' saved [36009/36009]

--2024-10-16 16:51:38-- https://apt.edatec.cn/pubkey.gpg
Connecting to 192.192.192.208:8118... connected.
Proxy request sent, awaiting response... 200 OK
Length: 1635 (1.6K) [application/octet-stream]
Saving to: '/tmp/eda-common/eda/edatec.gpg'

/tmp/eda-common/eda/edatec.gpg 100%[=====] 1.60K --.-KB/s in 0s

```

2. After the installation is complete, the system automatically reboots.
3. Execute the following command to check whether the firmware package is installed successfully.

```
dpkg -l | grep ed-
```

The result in the picture below indicates that the firmware package has been installed successfully.

```

pi@raspberrypi:~$ dpkg -l | grep ed-
ii  ed-hmt2120-101c-firmware      1.20240806.2      arm64      Firmware of EDATEC Software Package
ii  ed-linux-image-6.6.31-v8     2:1.20240805.2   arm64      EDATec Linux 6.6.31 for Raspberry Pi v8
ii  libparted-fs-resize0:arm64   3.5-3            arm64      disk partition manipulator - shared FS resizing lib
rary
ii  libshine3:arm64             3.1.1-2         arm64      Fixed-point MP3 encoding library - runtime files
ii  shared-mime-info             2.2-1           arm64      FreeDesktop.org shared MIME database and spec
ii  usr-is-merged                37~deb12u1      all        Transitional package to assert a merged-/usr system

```

## TIP

If you have installed the wrong firmware package, you can execute

`sudo apt-get --purge remove package` to delete it, where “package” is the package name.