



ED-HMI2002-101C

User Manual

by EDA Technology Co., Ltd

built: 2024-11-20

1 Hardware Manual

This chapter introduces the product overview, packing list, appearance, indicator and interface.

1.1 Overview

ED-HMI2002-101C is a 10.1-inch industrial HMI based on Raspberry Pi 4. According to different application scenarios and user needs, different specifications of RAM and SD card computer systems can be selected.

- RAM can choose 1GB, 2GB, 4GB and 8GB
- SD card can choose 32GB and 64GB

ED-HMI2002-101C provides HDMI, USB 2.0, USB 3.0 and Ethernet interfaces, supporting access to the network through Wi-Fi and Ethernet.

ED-HMI2002-101C integrates 10.1-inch LCD touch screen and is mainly used in industrial control and IOT.



1.2 Packing List

- 1x ED-HMI2002-101C Unit

1.3 Appearance

Introducing the functions and definitions of interfaces on each panel.

1.3.1 Front Panel

This section introduces functions and definitions of front panel.

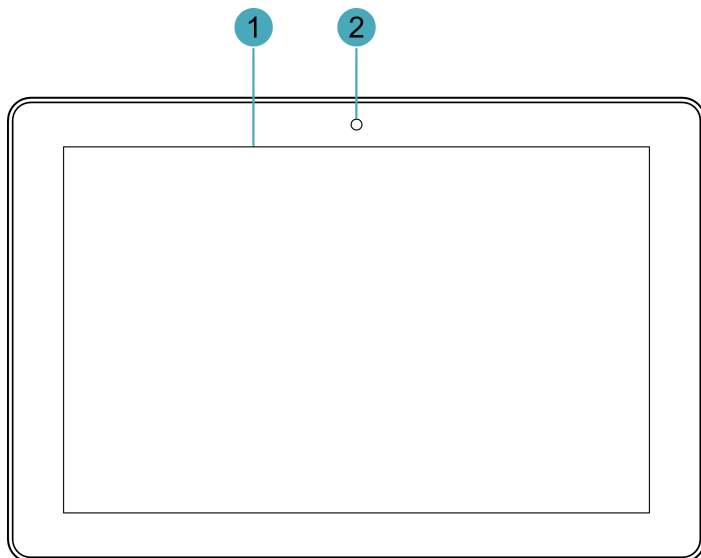

NO.	Function Definition
1	1 x LCD display, 10.1-inch LCD touch screen, which supports up to 1280x800 and multi-point capacitive touchscreen.
2	1 x camera (optional), 8 Megapixel front camera.

1.3.2 Rear Panel

This section introduces interfaces and definitions of rear panel.

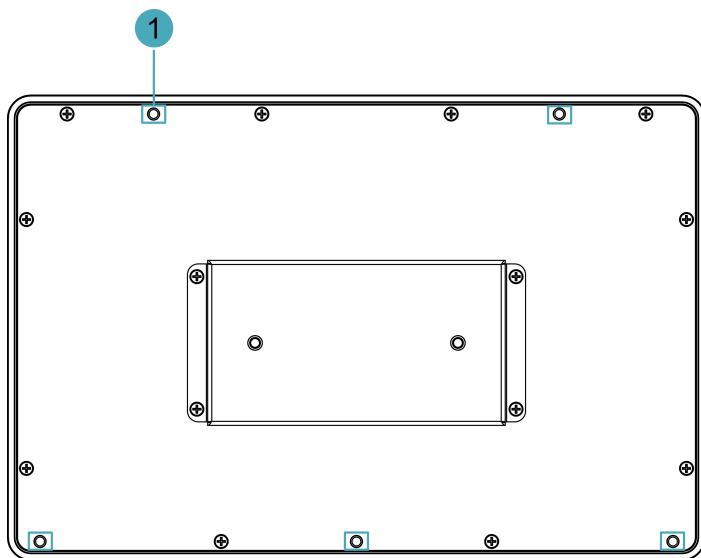

NO.	Function Definition
1	5 x installation holes of buckle, which are used to fix the buckles to the device for installation. You only need to use 4 installation holes during installation, and reserve one as a spare.

1.3.3 Side Panel

This section introduces interfaces and definitions of side panel.

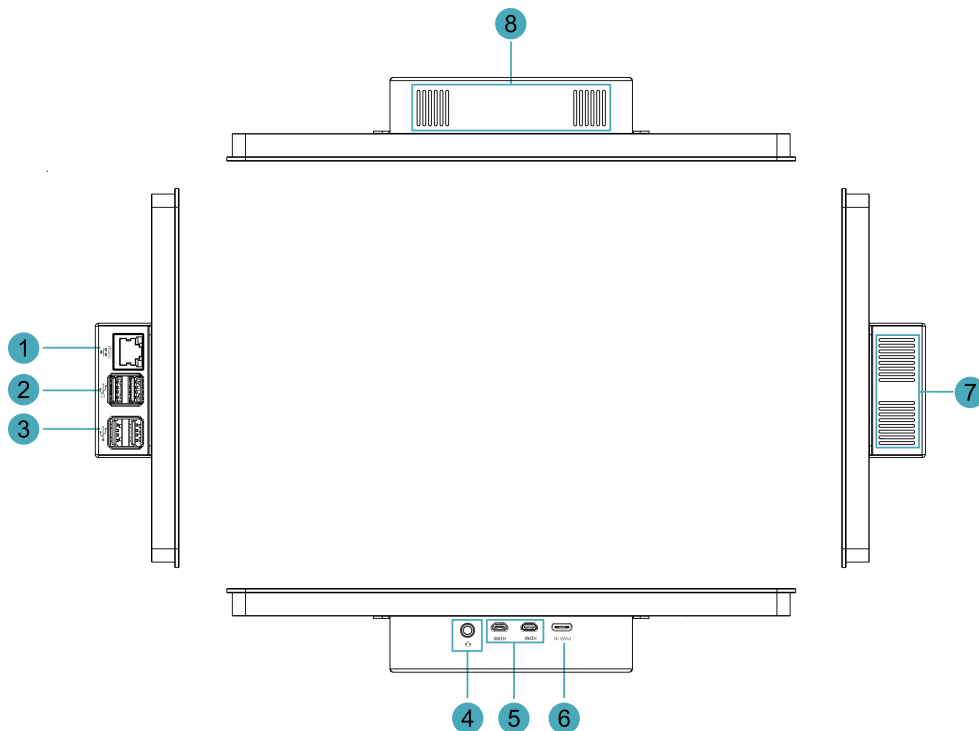

NO.	Function Definition
1	1 x Ethernet port (10/100/1000M adaptive), RJ45 terminal for Ethernet access.
2	2 x USB 3.0 ports, type-A connector, each channel supports up to 5Gbps.
3	2 x USB 2.0 ports, type-A connector, each channel supports up to 480Mbps.
4	1 x Audio In/Stereo Out, 3.5mm audio jack for microphone in and stereo out.
5	2 x HDMI ports, micro-HDMI connector, which can connect a display and supports 4K 60Hz.
6	1 x USB Type-C connector, which supports 5V 3A power input.
7	Heat dissipation holes, which help improve cooling performance.
8	Heat dissipation holes, which help improve cooling performance.

1.4 Indicator

This section introduces various statuses and meanings of indicators contained in ED-HMI2002-101C.

Indicator	Status	Description
Yellow indicator of Ethernet port	On	The Ethernet connection is in the normal state.
	Blink	The Ethernet connection is abnormal.
	Off	The Ethernet connection is not set up.
Green indicator of Ethernet port	On	The Ethernet connection is in the normal state.
	Blink	Data is being transmitted over the Ethernet port.

Indicator	Status	Description
	Off	The Ethernet connection is not set up.

1.5 Interface

Introducing the definition and function of each interface in the product.

1.5.1 Power Supply

The ED-HMI2002-101C includes one power input, and the silkscreen is “PWR IN”. The connector is USB Type-C, which supports 5V 3A power input.

TIP

In order for Raspberry Pi 4 to achieve better performance, it is recommended to use a 5V 3A power adapter.

1.5.2 1000M Ethernet

ED-HMI2002-101C includes one adaptive 10/100/1000M Ethernet port, RJ45 terminal with

indicator, and the silkscreen is “1000M”, which is used to access the Ethernet. The pins corresponding to the terminals are defined as follows :

	Pin ID	Pin Name
	1	TX1+
	2	TX1-
	3	TX2+
	4	TX2-
	5	TX3+
	6	TX3-
	7	TX4+
	8	TX4-

1.5.3 Audio

The ED-HMI2002-101C device contains 1 audio interface, 3.5mm four-section headphone terminal, and the silkscreen is “”, supports OMTP specification stereo headphone output and single channel microphone recording.

1.5.4 HDMI

ED-HMI2002-101C includes 2 HDMI ports, and the silkscreen is “HDMI”.The connector is micro-HDMI, which can connect to HDMI displays and supports up to 4Kp60.

1.5.5 USB 2.0

ED-HMI2002-101C includes 2 USB 2.0 ports, and the silkscreen is “”.The connector is USB Type-A, which can connect to standard USB 2.0 peripherals and supports up to 480Mbps.

1.5.6 USB 3.0

ED-HMI2002-101C includes 2 USB 3.0 ports, and the silkscreen is “”.The connector is USB Type-A, which can connect to standard USB 3.0 peripherals and supports up to 5Gbps.

2 Installing Device

This chapter describes the specific operations for installing the device.

2.1 Installing Raspberry Pi 4 (optional)

If the product model purchased by the customer does not include Raspberry Pi 4, Raspberry Pi 4 needs to be installed first.

Preparation :

- ED-HMI2002-101C and SD card have been obtained from the packaging box.
- Raspberry Pi 4 is ready.
- A cross screwdriver has been prepared.

Steps :

1. Insert the SD card into SD card slot of Raspberry Pi 4.

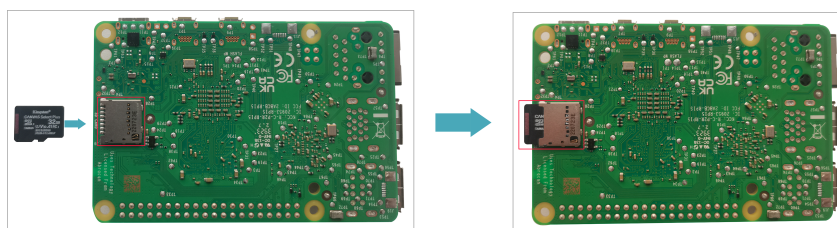

2. Use a screwdriver to loosen 4 M3 screws on ED-HMI2002-101C case counterclockwise, and remove the case.

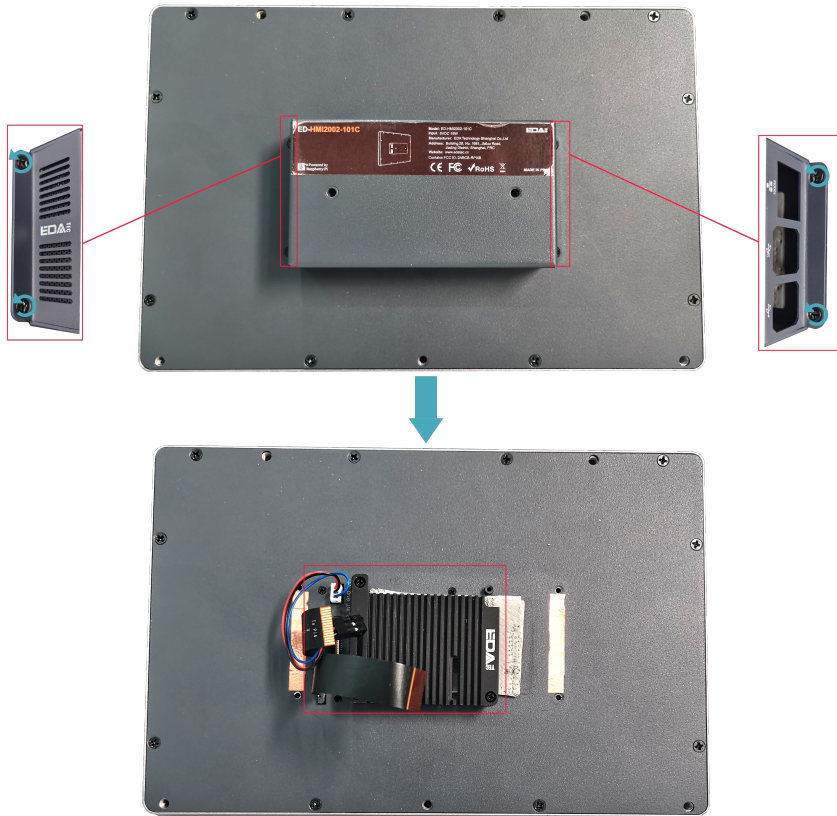

3. Use a screwdriver to loosen 3 M2.5 screws on ED-Pi4PCOOLER counterclockwise, and remove the cooler.

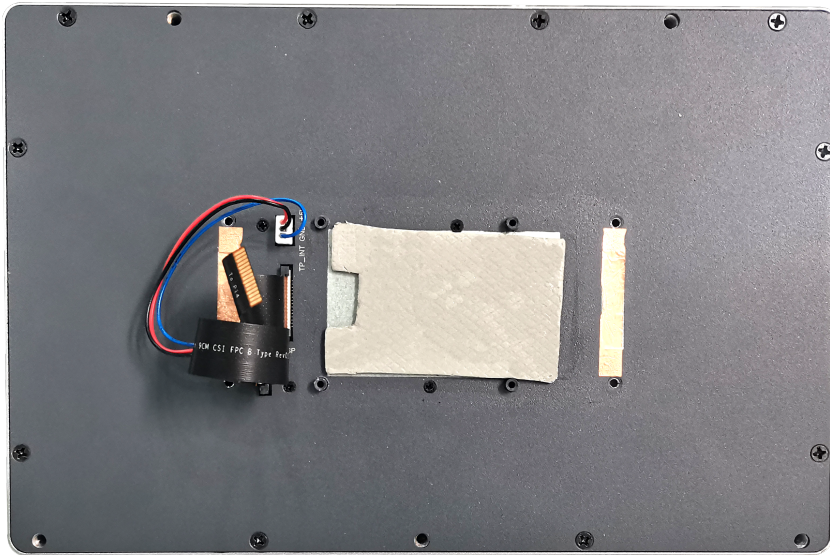
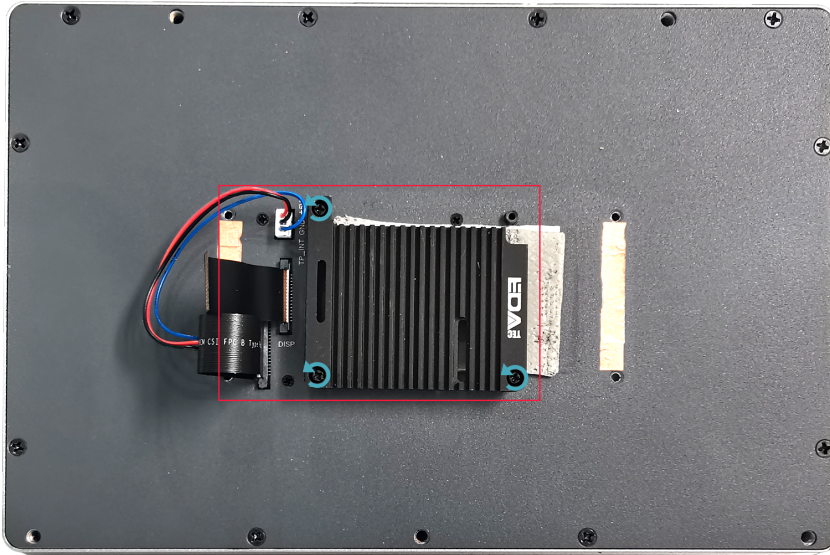

TIP

- ED-Pi4PCOOLER is an optional cooling accessory.
- If there is a film of thermal conductive silicone, please remove it .

- Place the Raspberry Pi 4 on the back of the LCD screen so that the installation holes of the Raspberry Pi 4 can align with the four stud holes on the back of the LCD screen.



- Pass the FPC cable through the reserved hole on the ED-Pi4PCOOLER.

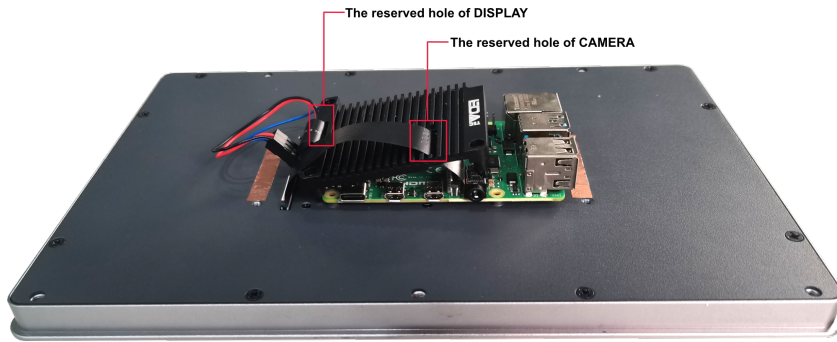

6. Plug the FPC cable into the CAMERA and DISPLAY ports of the Raspberry Pi 4 respectively.

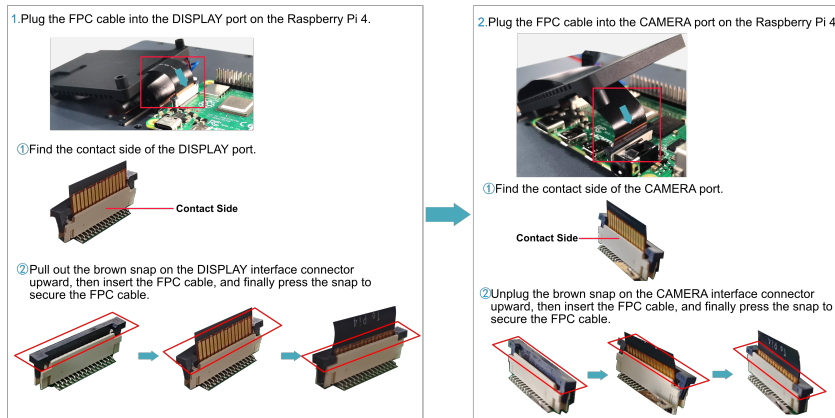

7. Make 3 mounting holes of ED-Pi4PCOOLER aligning with the mounting holes of Raspberry Pi 4.



8. Insert 3 M2.5*12 screws and 1 M2.5*5 screw, then tighten them clockwise to secure the Raspberry Pi 4 and ED-Pi4PCOOLER to the back side of the LCD screen.

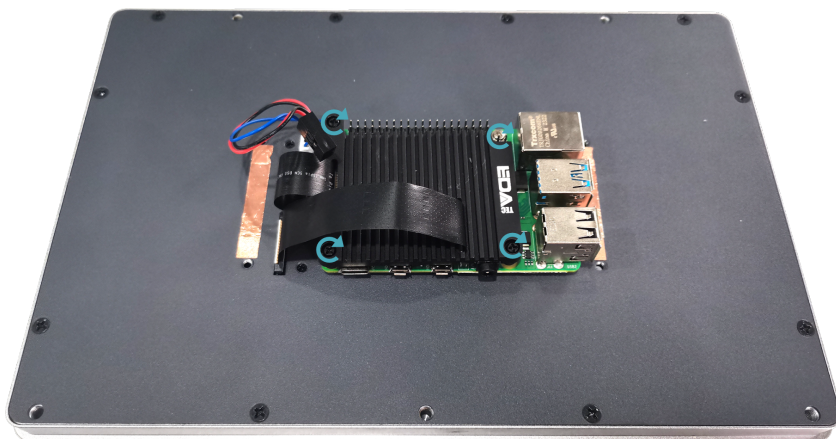

9. Plug the power cord into the corresponding 40-Pin on the Raspberry Pi 4.

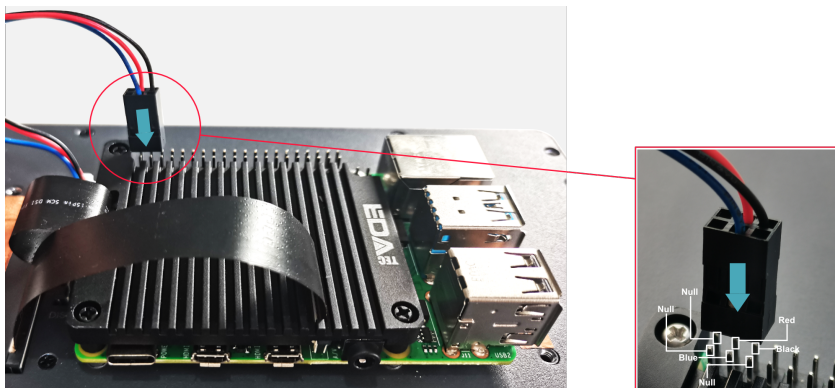

10. Cover the case, insert 4 M3 screws, and tighten clockwise to fix the case to the back of the LCD screen.

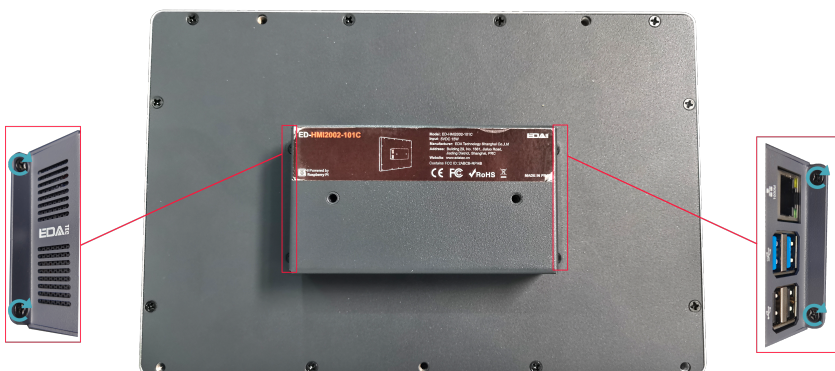

2.2 Embedded Installation

ED-HMI2002-101C device supports embedded front installation and the optional ED-ACCHMI-Front accessory kit (includes 4xbuckles, 4xM4*10 screws and 4xM4*16 screws).

Preparation :

- ED-ACCHMI-Front accessory kit has been obtained (contains 4xbuckles, 4xM4*10 screws and 4xM4*16 screws).
- A cross screwdriver has been prepared.

Steps :

1. Ensure the opening size of the cabinet according to the size of ED-HMI2002-101C, as shown in the figure below.

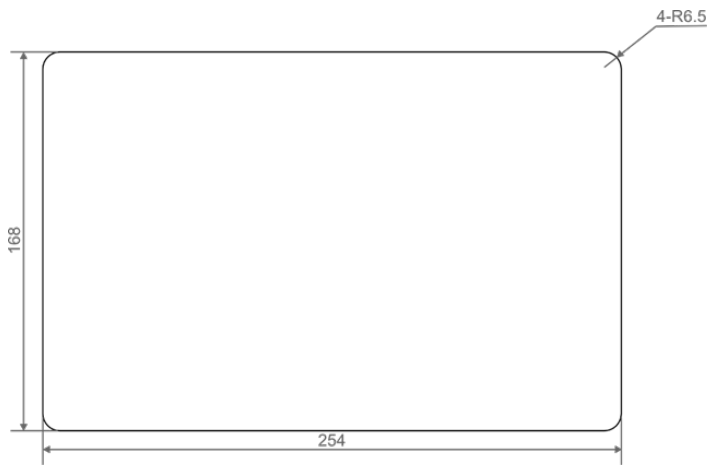

2. Drill a hole on the cabinet according to the hole size of step1.
3. Embed the ED-HMI2002-101C into the cabinet from the outside.

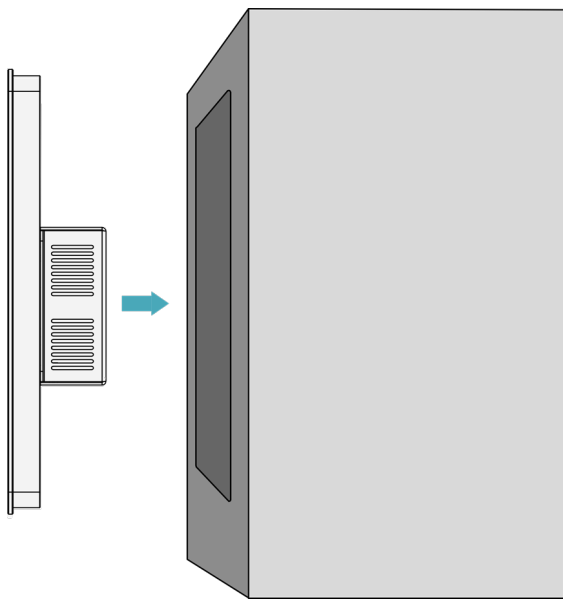

4. Align the screw hole (unthreaded hole) of the buckle with the buckle installation hole on the device.

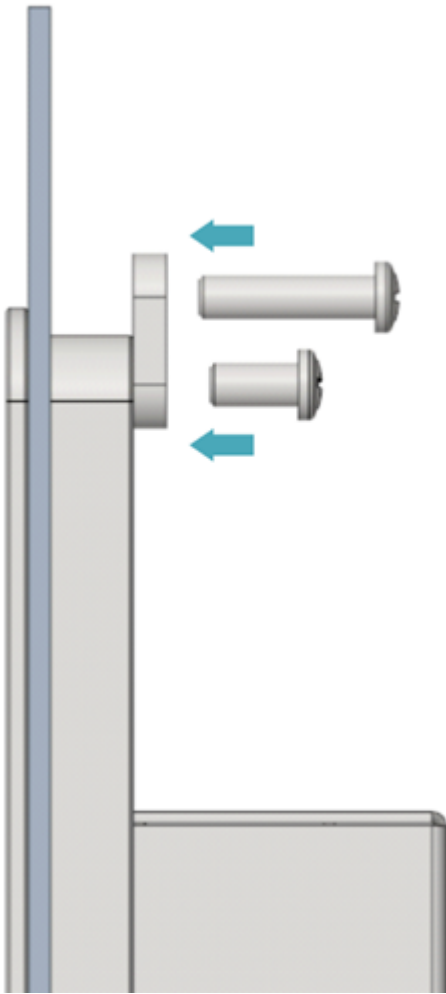

5. Use 4 M4*10 screws to pass through the buckle and tighten it clockwise to fix the buckle to the device; then use 4 M4*16 screws to pass through the screw hole (threaded hole) of the buckle and tighten clockwise to the end through the buckles.

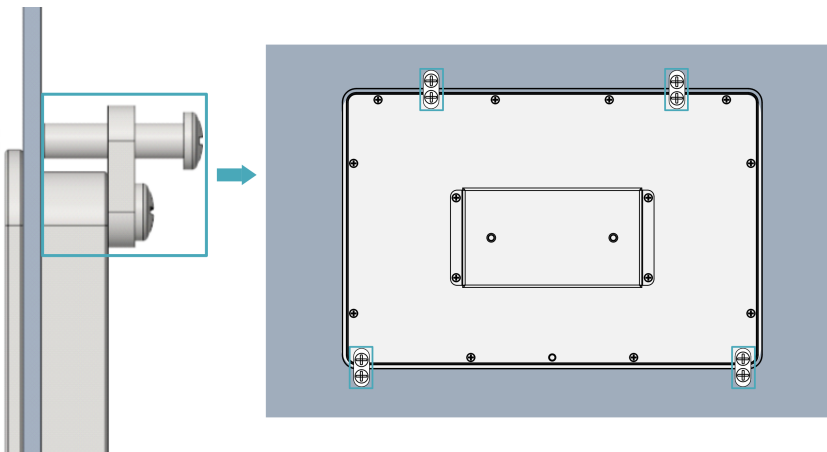

3 Booting The Device

This chapter introduces how to connect cables and boot the device.

3.1 Connecting Cables

This section describes how to connect cables.

Preparation :

- Accessories such as display, mouse, keyboard and power adapter that can be used normally have been ready.
- A network that can be used normally.
- Get the HDMI cable and network cable that can be used normally.

Schematic diagram of connecting cables:

Please refer to [1.5 Interface](#) for the pin definition of each interface and the specific method of wiring.

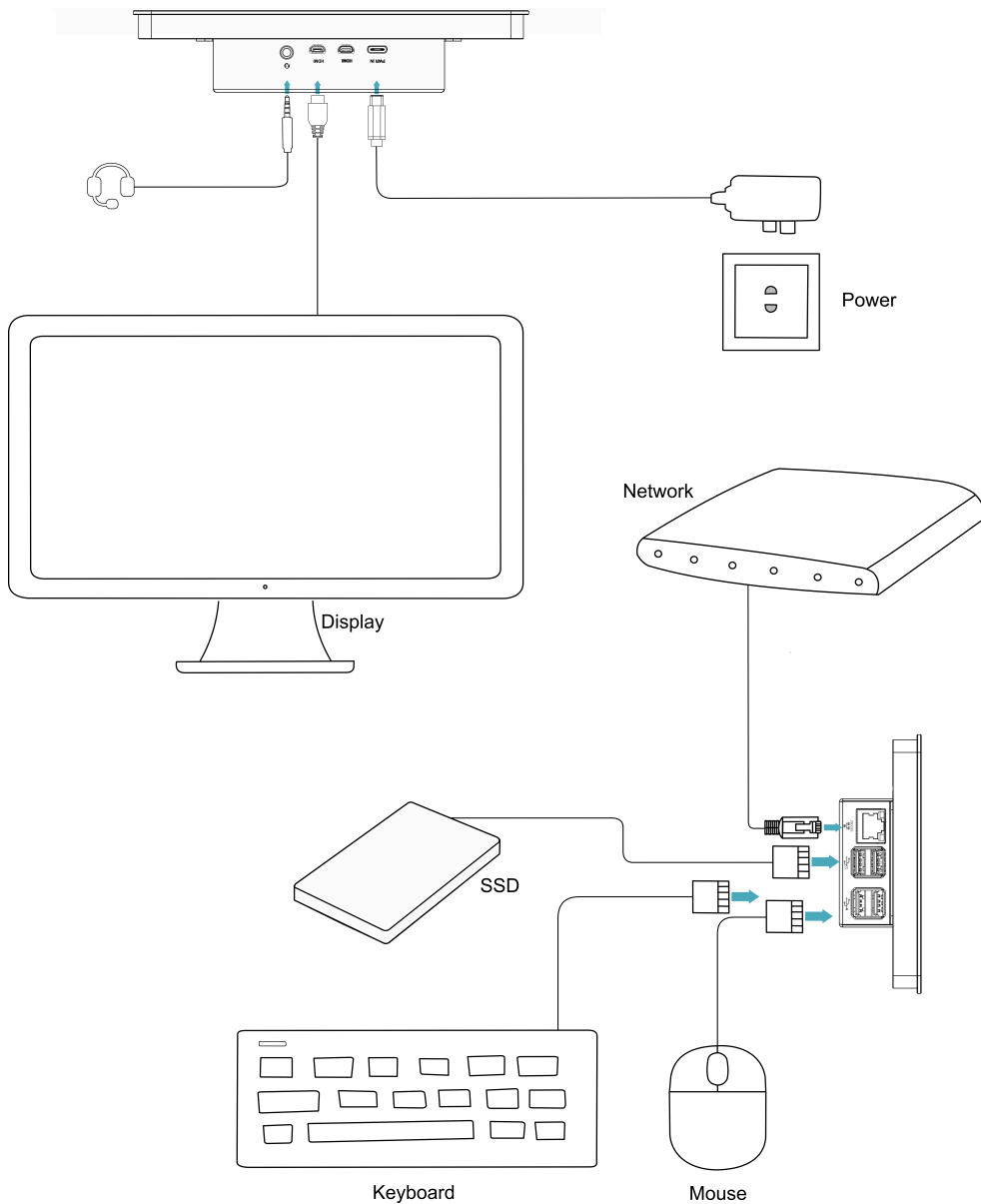

4.2 Booting The System For The First Time

ED-HMI2002-101C has no power switch. After the power supply is connected, the system will start. The product is installed with the Desktop version system when it leaves the factory. After the device is started, it will directly enter the desktop.

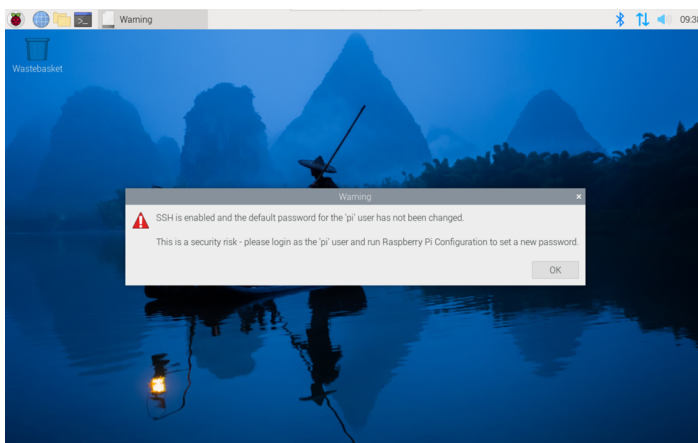

TIP

Default username is `pi` , Default password is `raspberrypi` .

For more information about Raspberry Pi 4 configuration operations, please refer to the documentation on the Raspberry Pi official website. The documentation path is: [Raspberry Pi \(https://www.raspberrypi.com/documentation/\)](https://www.raspberrypi.com/documentation/) .

4 Remote Login

This chapter introduces how to log in the device remotely.

4.1 Finding Device IP

Finding Device IP

4.2 Connecting To The Device Desktop Through VNC

After the device starts normally, you can choose to remotely connect to the device through VNC to configure or debug it.

Preparation:

- The RealVNC Viewer tool has been installed on PC.
- ED-HMI2002-101C has been connected to the network through the router.
- IP address of ED-HMI2002-101C has been get.
- The VNC function in the ED-HMI2002-101C system has been turned on, as shown in the following figure.

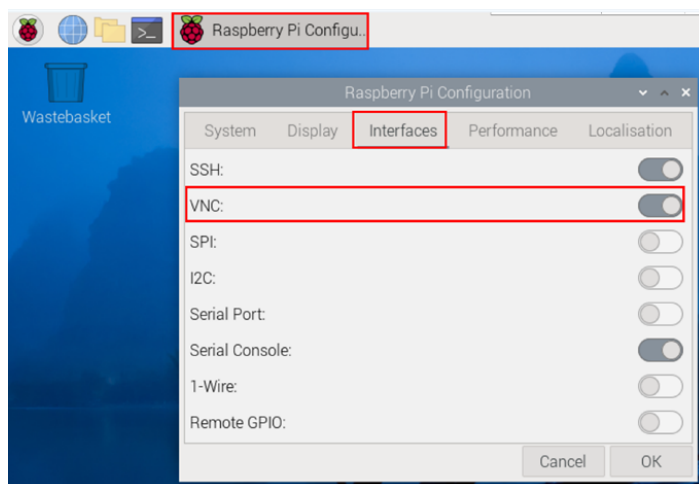

Steps :

1. Open RealVNC Viewer and select "New connection..." in the File in the menu bar to open the window for creating a connection, as shown in the following figure.

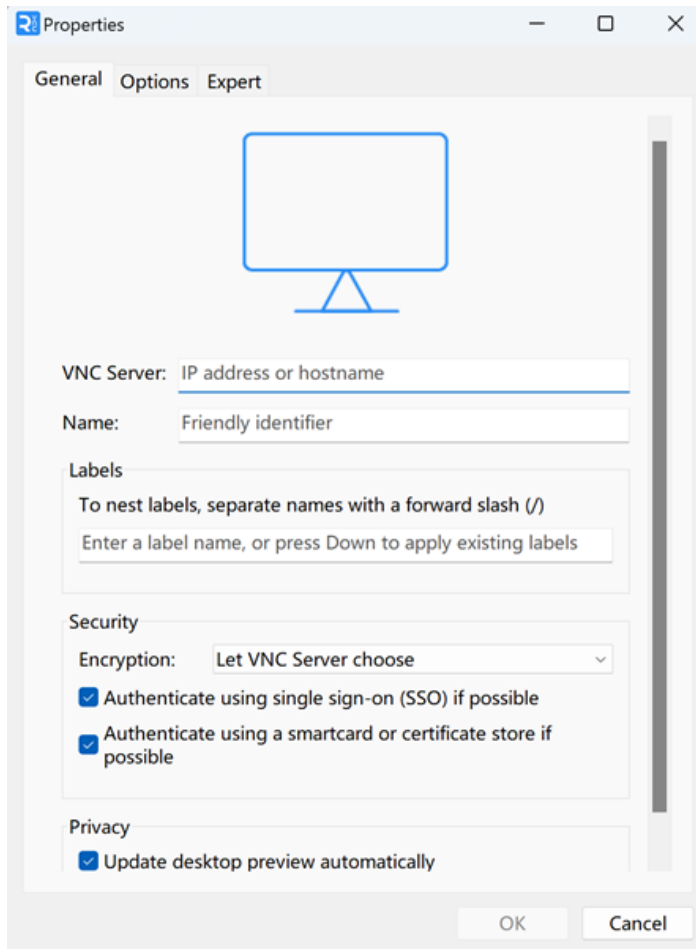

2. After entering the IP address of ED-HMI2002-101C, click "OK".

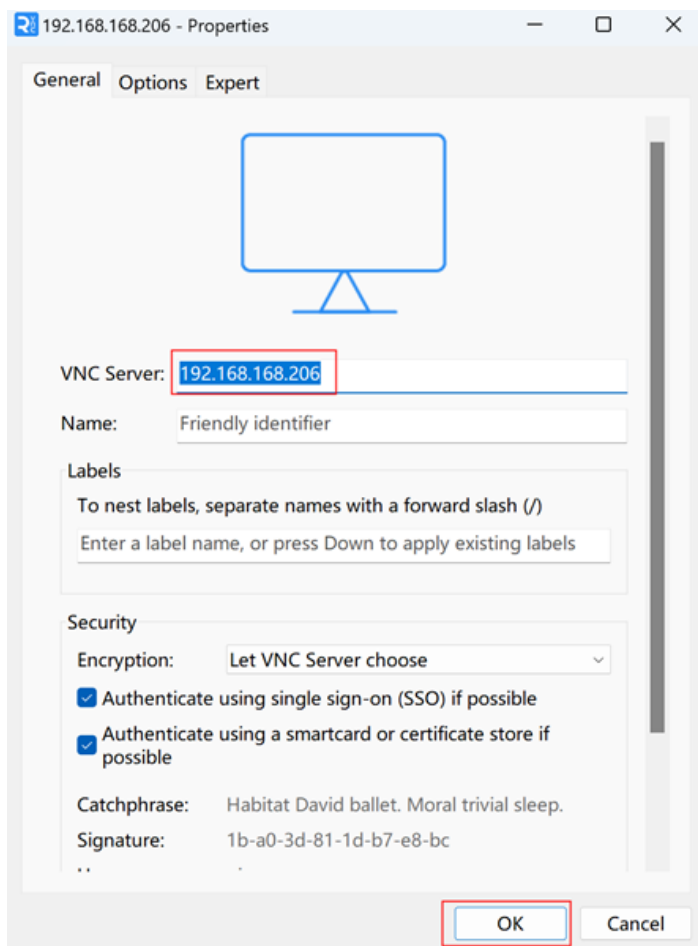

3. Enter the username and password in the Authentication prompt box that pops up.

TIP

Default username is `pi` , Default password is `raspberrypi` .

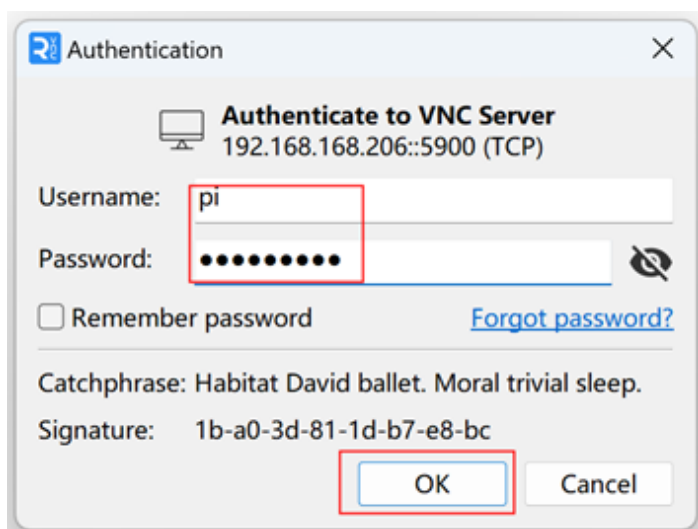

4. Select "OK" to log in and connect to the remote desktop.

